

K2-621G Catch Basin

K2-621G Catch Basin

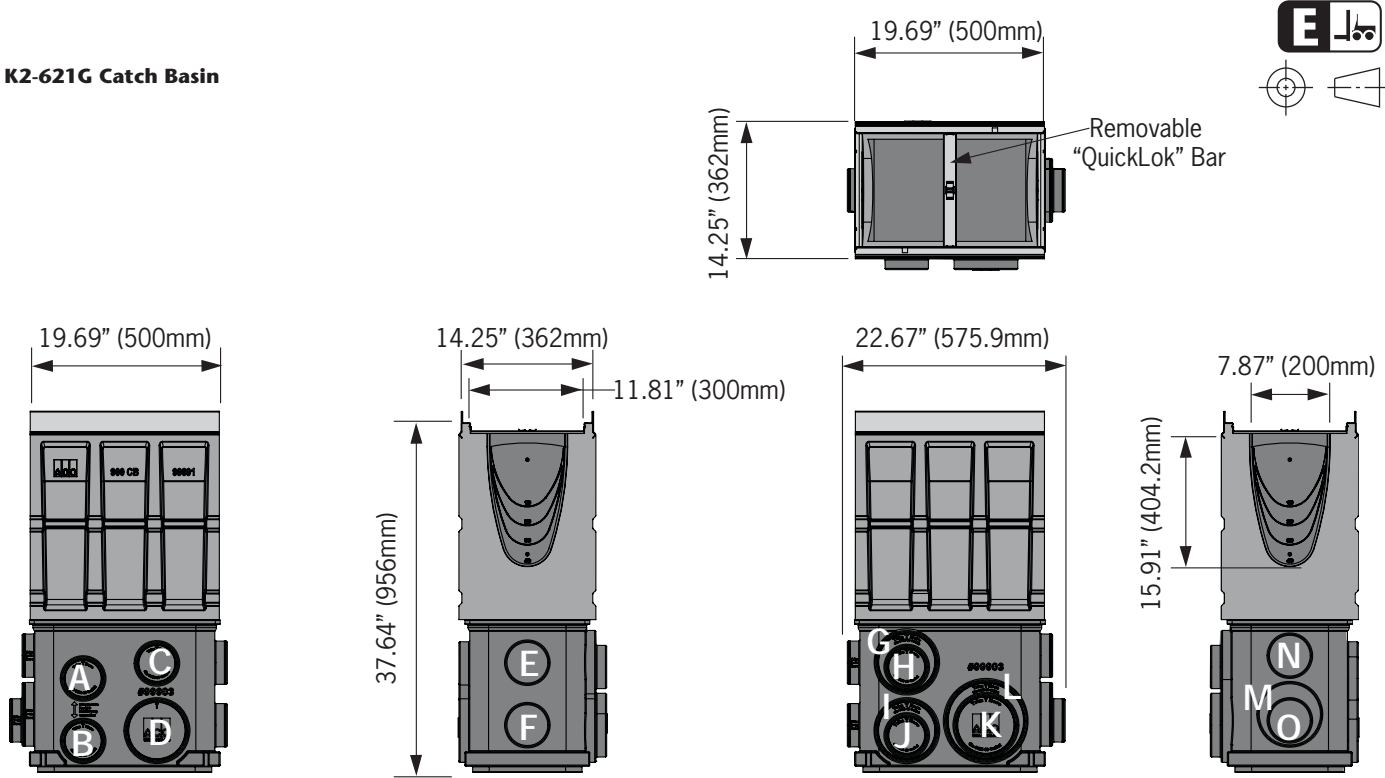

Outlet flow rates

Outlet	Product	Outlet size (Sch. 40)	Invert Depth	GPM	CFS
A	Type K2-621G	4" round	29.80"	287	0.64
B	Type K2-621G	4" round	36.29"	319	0.71
C	Type K2-621G	4" round	28.22"	279	0.62
D	Type K2-621G	6" round	36.29"	707	1.57
E	Type K2-621G	4" round	28.37"	280	0.62
F	Type K2-621G	4" round	34.87"	312	0.70
G	Type K2-621G	6" round	29.15"	626	1.40
H	Type K2-621G	4" round	28.59"	281	0.63
I	Type K2-621G	6" round	36.28"	707	1.57
J	Type K2-621G	4" round	35.72"	316	0.70
K	Type K2-621G	6" round	35.72"	701	1.56
L	Type K2-621G	8" round	36.28"	1237	2.76
M	Type K2-621G	6" round	34.78"	690	1.54
N	Type K2-621G	4" round	27.65"	276	0.61
O	Type K2-621G	4" round	34.36"	310	0.69

Notes:

1. These are the pipe flow rates at the specified outlet, **NOT** channel flow rates.
*Flow rates without trash bucket - using trash bucket or filter bag reduces flow rates.
2. 4" diameter foul air trap, part# 90854, can be fitted to catch basin base at outlet positions A/B and E/F.
3. Fits KlassikDrain K200 systems.

Trash Bucket

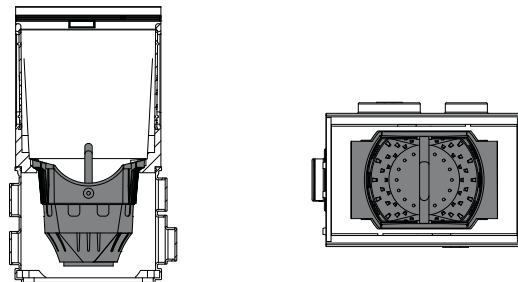
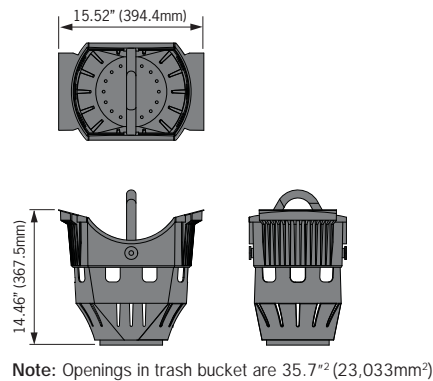

Note: Trash bucket position within K2-621G catch basin body and base

Supplied By:



877-903-7246

www.trenchdrainsupply.com



ACO Specification Information

ACO DRAIN

K2-621G Catch Basin



ACO Specification Information

Description	Part No.	Invert Depth		Weight lbs.
		inches	mm	
Type K2-621G Catch basin assembly - top, removable "QuickLok" bar, trash bucket & base	94620	37.40	950	91.0
Catch Basin Components				
Type 600 optional riser	99902	12.00	304.8	10.0
Foul air trap - fits both Type 900 & Type 600 basins	90854	-	-	1.2
QuickLok grate removal tool	01318	-	-	0.5

Optional riser detail (Part# 99902)

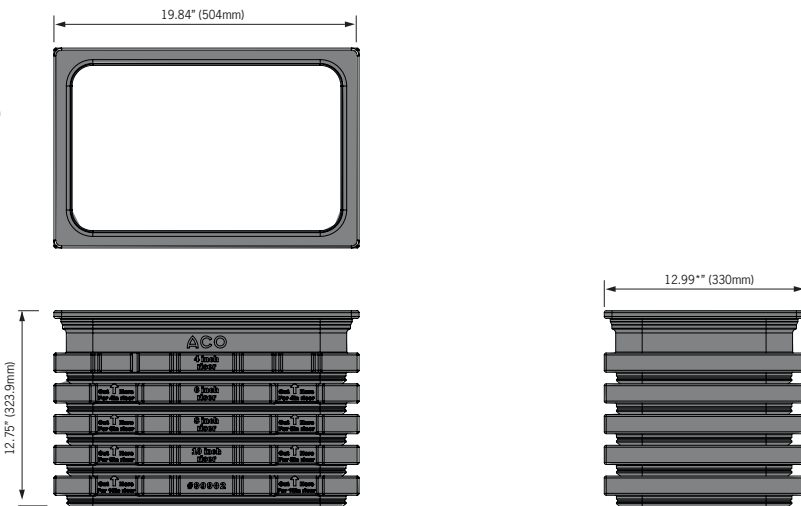

Notes:

1. Riser can be cut down in 1" (25mm) increments.
2. Addition of riser will alter the outflow rates of base as shown on table overleaf.

Specifications		Salt proof	YES	Optional Riser	
		Dilute acid and alkali resistant	YES	Optional riser can be used between polymer concrete top unit and LLDPE base unit. Use of riser is determined by access and local building codes.	
General		The nominal clear opening shall be 14.25" (362mm) wide by 19.69" (500mm) long. Overall width of 22.67" (575.9mm) by 37.64" (956mm) long. Type K2-621G catch basin assembly has overall depth of 37.64" (956mm). Polymer concrete top units shall incorporate a cast in galvanized steel frame manufactured with drillouts for channel connection and have a wall thickness of at least 0.59" (15mm). Top units shall have horizontal cast in anchoring key features on the outside to ensure maximum mechanical bond to the surrounding bedding material and pavement surface. The base unit shall be a LLDPE plastic molding and incorporate molded plastic pipe stubbs to facilitate pipe connection.		Grates	Grates shall be specified. See separate ACO Spec Info grate sheets for details. After removal of grates and 'QuickLok' bar there shall be uninterrupted access to the catch basin to aid maintenance.
Materials		The top unit body shall be manufactured from polyester polymer concrete with minimum properties as follows:		Installation	
Compressive strength:	14,000 psi			The trench drain/catch basin system shall be installed in accordance with the manufacturer's installation instructions and recommendations.	
Flexural strength:	4,000 psi				
Water absorption	0.07%				
Frost proof	YES				

ACO Polymer Products, Inc.

Northeast Sales Office
P.O. Box 245
Chardon, OH 44024
Tel: (440) 285-7000
Toll free: (800) 543-4764
Fax: (440) 285-7005

West Sales Office
P.O. Box 12067
Casa Grande, AZ 85130
Tel: (520) 421-9988
Toll Free: (888) 490-9552
Fax: (520) 421-9899

Southeast Sales Office
4211 Pleasant Road
Fort Mill, SC 29708
Toll free: (800) 543-4764
Fax: (803) 802-1063



Electronic Contact:
info@ACODrain.us
www.ACODrain.us



© April 15, 2013 ACO Polymer Products, Inc. This information is believed to be accurate but it is not guaranteed to be so. We cannot assume liability for results that buyer obtains with our product since conditions of use are beyond the control of the company. It is the customer's responsibility to evaluate suitability and safety of product for his own use. ACO Polymer Products Inc. reserves the right to change the product and specifications without notice.